



CARICATORI FORESTALI

FORESTAL LOADERS

DANIELE & GIRAUDDO



All'interno il nuovo DAGI ELECTRIC SYSTEM per il totale controllo elettrico proporzionale
– Behind the new electric control system
– À l'intérieur du nouveau système électrique proportionnel

DG80F Z30



	Code	DGF001DG
	KNm	8
	N°	1
	M	3,00
	Kg	200
	°	20
	°	360
	Lt/min	20
	Kg	380



DG80F

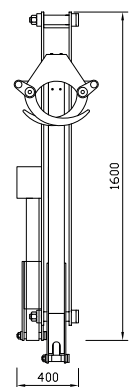
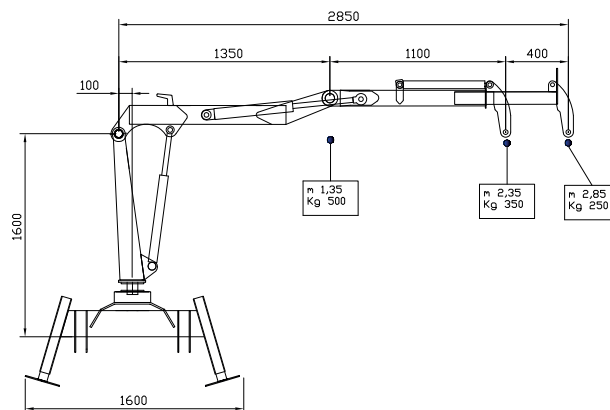
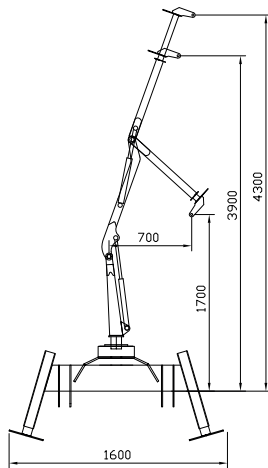

Il modello **DG80F Z3** è adatto prevalentemente per trattori di piccole dimensioni, piccoli e medi rimorchi e motoagricole cassonate, questo grazie alle sue dimensioni compatte e al suo peso contenuto che ne fanno una macchina agile, comoda e di immediato utilizzo.

The model **DG80F Z3** is mainly suitable for small tractors, small and medium trailers and motorized agricultural trailers, this thanks to its compact size and its low weight that make it an agile, comfortable and easy to use machine.

Le modèle **DG80F Z3** est principalement adapté pour les petits tracteurs, les petites et moyennes remorques et les remorques agricoles motorisées, ceci grâce à sa taille compacte et à son faible poids qui en font une machine agile, confortable et facile à utiliser.

DG120F Z35



	Code	DGF002DG
	KNm	12
	N°	1
	M	3,50
	Kg	300
	°	20
	°	360
	Lt/min	20
	Kg	650



DG120F

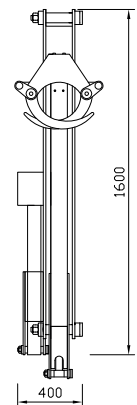
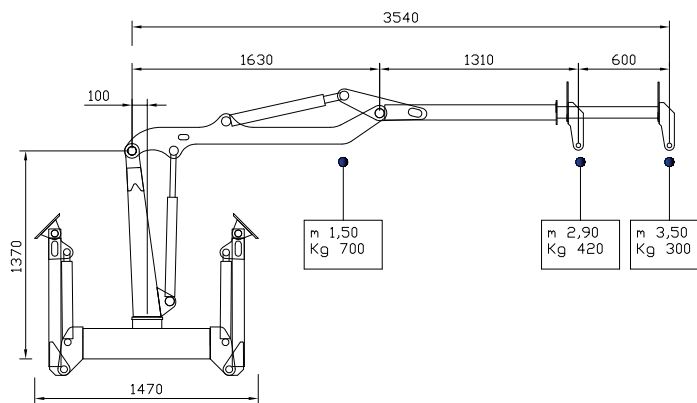
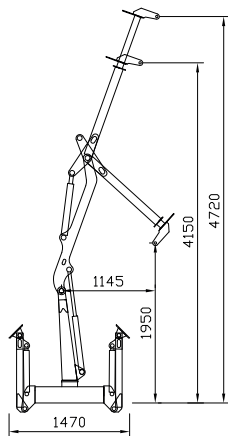

Il modello **DG120F Z35** è adatto per trattori di piccole e medie dimensioni, su rimorchi forestali di media lunghezza adatto a movimentare piccole e medie quantità di legname. Si distingue per la sua struttura robusta di chiara ispirazione ai modelli più grandi con un peso contenuto per renderlo maneggevole su ogni mezzo.

The model **DG120F Z35** is suitable for small and medium-sized tractors, on medium-length forest trailers suitable for handling small and medium quantities of timber. It stands out for its robust structure of clear inspiration to the larger models with a low weight to make it manageable on every vehicle.

Le modèle **DG120F Z35** convient aux tracteurs de petite et moyenne taille, sur des remorques forestières de longueur moyenne adaptées à la manutention de petites et moyennes quantités de bois. Il se distingue par sa structure robuste d'inspiration claire pour les plus grands modèles avec un poids faible pour le rendre gérable sur chaque véhicule.

DG180F Z40



	Code	DGF003DG
	KNm	20
	N°	2
	M	4,00
	Kg	350
	°	20
	°	400
	Lt/min	30
	Kg	750



D180F

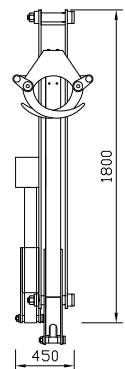
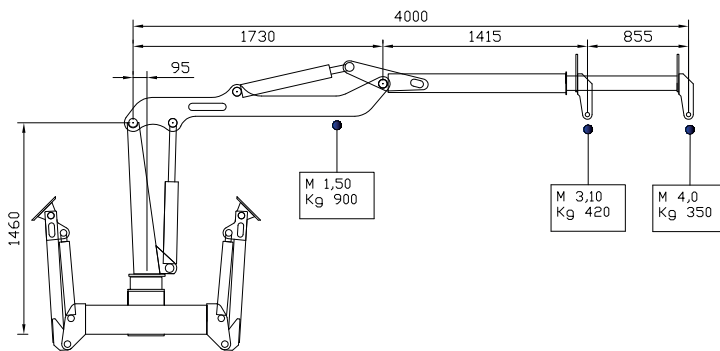
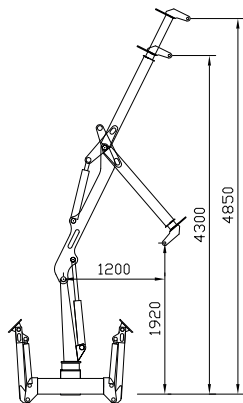

Il modello **DG180F Z4** si adatta bene a trattori di media potenza, nonché su rimorchi forestali di medie dimensioni, con la rotazione a cremagliera precisa ed affidabile consente grandi prestazioni in rotazione oltre che un'elevata capacità di carico per tutta la sua lunghezza garantendo un ottimo compromesso per l'operatore che si inserisce tra l'hobby e il professionale.

The **DG180F Z4** model is well suited to medium-powered tractors, as well as medium-sized forest trailers, with precise and reliable rack rotation, allowing high performance in rotation as well as a high load capacity along its entire length, guaranteeing an excellent compromise for the operator that fits between the hobby and the professional.

Le modèle **DG180F Z4** est bien adapté aux tracteurs de moyenne puissance, ainsi qu'aux remorques forestières de taille moyenne, avec une rotation précise et fiable des crémaillères, permettant une rotation élevée ainsi qu'une capacité de charge élevée sur toute sa longueur, garantissant un excellent compromis pour l'opérateur qui correspond entre le passe-temps et le professionnel.

DG280F Z50



	Code	DGF004DG
	KNm	25
	N°	2
	M	5,00
	Kg	400
	°	20
	°	400
	Lt/min	35
	Kg	900

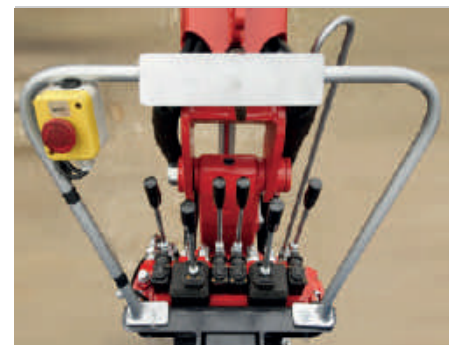

DG280F

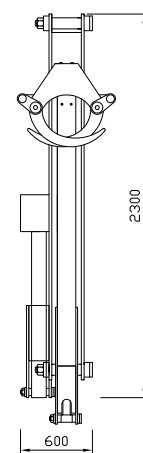
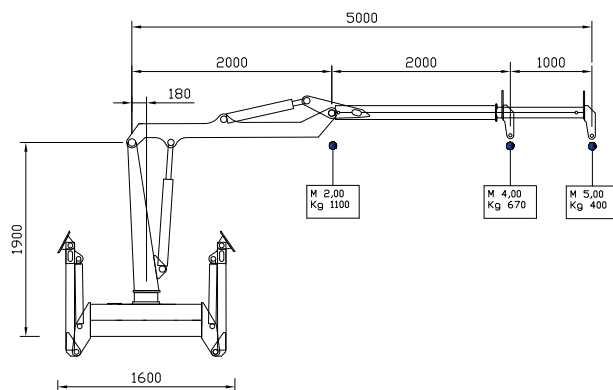
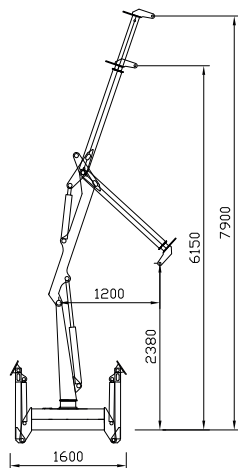

Il modello **DG280F Z5** si adatta bene a trattori di media/grande potenza, nonché su rimorchi forestali di più grandi dimensioni, con la rotazione a cremagliera precisa, affidabile e più potente dei modelli precedenti permette di avere un mix di ottime prestazioni per garantire un lavoro sicuro ai professionisti del settore che necessitano di spostare ingenti quantità di legname.









The **DG280F Z5** model is well suited to medium/large power tractors, as well as on larger forest trailers, with precise, reliable and more powerful rack rotation than previous models, allowing a mix of excellent performance to guarantee a job safe for professionals in the sector who need to move large quantities of timber.

Le modèle **DG280F Z5** est bien adapté aux tracteurs de moyenne et grande puissance, ainsi qu'aux grandes remorques forestières, avec une rotation précise, fiable et plus puissante que les modèles précédents, permettant un mélange d'excellentes performances pour garantir un travail sans danger pour les professionnels du secteur qui doivent déplacer de grandes quantités de bois.

DG320F Z60

NEW



	Code	DGF005DG
	KNm	25
	N°	4
	M	6,00
	Kg	400
	°	20
	°	400
	Lt/min	35
	Kg	1050



DG320F

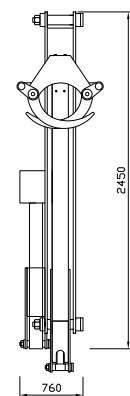
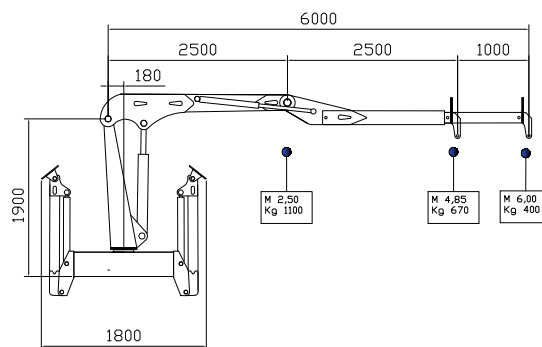
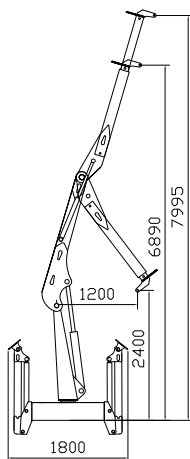

Il modello DG320F Z6 si adatta bene a trattori di media/grande potenza, nonché su rimorchi forestali di grandi dimensioni; presenta una doppia cremagliera per la rotazione e un doppio cilindro sul braccio di carico che permettono di risaltare le doti di una macchina che garantisce elevate prestazioni in termini di carico coadiuvate da un peso eccezionale in grado di installarla su un'ampia gamma di potenze.

The DG320F Z6 model is well suited to medium/large power tractors as well as to large forest trailers; it has a double rack for the rotation and a double cylinder on the loading arm that allow to highlight the qualities of a machine that guarantees high performance in terms of load supported by an exceptional weight able to install it on a wide range of powers.

Le modèle DG320F Z6 est bien adapté aux tracteurs de moyenne/grande puissance ainsi qu'aux grandes remorques forestières; il dispose d'un double crémaillère pour la rotation et d'un double cylindre sur le bras de chargement qui permettent de mettre en évidence les qualités d'une machine qui garantit de hautes performances en charge soutenue par un poids exceptionnel capable de l'installer sur un large éventail de puissances.

DG420F Z70



	Code	DGF006DG
	KNm	25
	N°	4
	M	7,00
	Kg	400
	°	20
	°	400
	Lt/min	35
	Kg	1150



DG420F

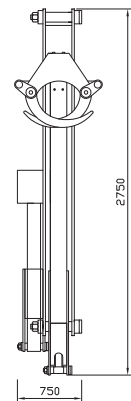
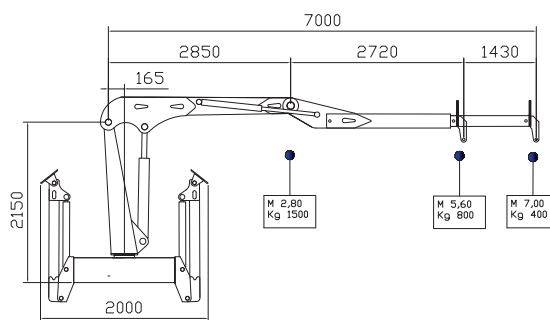
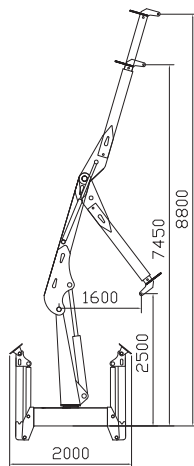

Il modello **DG420F Z7** si adatta bene a trattori di grande potenza, nonché su rimorchi forestali di grandi dimensioni; è una macchina a grande scabrezza con elevate capacità di carico adatta per lo spostamento di grandi quantità di legno per i professionisti del settore, si distingue per la robustezza della sua struttura unita ad un peso complessivo ultra-limitato.

The **DG420F Z7** model is well suited to high-powered tractors as well as to large forest trailers; is a large-reach machine with high load capacity suitable for the movement of large quantities of wood for professionals, is distinguished by the robustness of its structure combined with an ultra-limited overall weight.

Le modèle **DG420F Z7** est bien adapté aux tracteurs de grande puissance ainsi qu'aux grandes remorques forestières; est une machine de grande portée avec une capacité de charge élevée adaptée au déplacement de grandes quantités de bois pour les professionnels, se distingue par la robustesse de sa structure combinée à un poids global ultra-limité.

DG380F Z50 – DG480F Z60



	Code	DGF013DG	DGF014DG
	KNm	30	30
	N°	4	4
	M	5,00	6,00
	Kg	700	700
	°	20	20
	°	400	400
	Lt/min	40	55
	Kg	1300	1400



DG380F

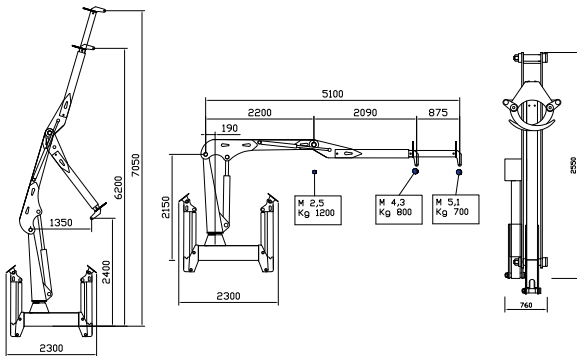

DG480F

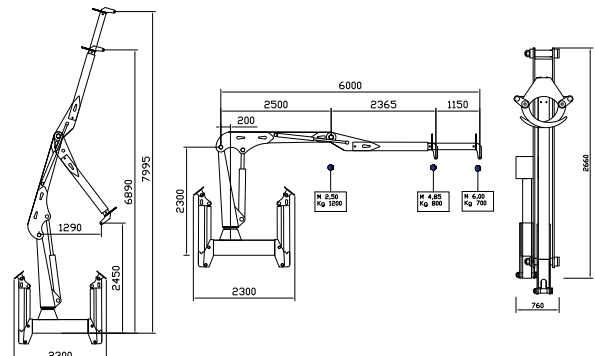

I modelli DG380FP e DG480FP sono gru forestali altamente professionali con una struttura importante in grado di assicurare potenze di carico molto elevate ad estensioni notevoli. Sono adatte a trattori di medie/grandi potenze, presentato un ancoraggio a sistema rapido semi-fisso in quanto il loro peso è notevole. Vengono impiegate prevalentemente dai professionisti del settore e laddove è necessaria la movimentazione di tronchi di peso e dimensioni molto grandi.

The DG380FP and DG480FP models are highly professional forest cranes with an important structure capable of ensuring very high load capacities with considerable extensions. They are suitable for medium/large power tractors, presented with a semi-fixed fast system anchor because their weight is considerable. They are mainly used by professionals in the sector and where it is necessary the handling of logs of very large weight and size.

Les modèles DG380FP et DG480FP sont des grues forestières hautement professionnelles avec une structure importante capable d'assurer des capacités de charge très élevées avec des extensions considérables. Ils conviennent aux tracteurs de puissance moyenne/grande, présentés avec un ancrage de système rapide semi-fixe parce que leur poids est considérable. Ils sont principalement utilisés par des professionnels du secteur et où il est nécessaire de manipuler des bûches de très gros poids et de grande taille.

CARICATORE FORESTALE – FORESTRY CRANE – GRUE FORESTIERE

SERIE "L"











- stabilizzatori idraulici comandati singolarmente;
- distributore idraulico a due cloche e tre/quattro leve;
- sistema di attacco per carro forestale o al sollevatore;
- sistema di rotazione a 400° con cremagliera in bagno d'olio;
- valvole di sicurezza sui cilindri di carico;
- sistema di parallelogramma sul secondo braccio;
- perni su boccole antiusura;
- braccio terminale telescopico sul modello DG-K600.



- individually controlled hydraulic stabilizers;
- two-cloche and three/four-lever hydraulic distributor;
- attachment system for the forest trailer or three point hitch;
- 400° rotation system with oil bath rack;
- safety valves on the loading cylinders;
- parallelogram system on the second arm;
- pins on wear-resistant bushes;
- telescopic terminal arm on the DG-K600 model.



- stabilisateurs hydrauliques à commande individuelle;
- distributeur hydraulique à deux cloche et à trois/quatre leviers;
- système de fixation pour le remorque forestier ou attelage troisième point;
- système de rotation de 400° avec support de bain d'huile;
- des soupapes de sûreté sur les cylindres de chargement;
- système de parallélogramme sur le second bras;
- des goupilles sur les bagues résistantes à l'usure;
- bras terminal télescopique sur le modèle DG-K600.

Mod.									
	Code	KNm	N°	m	Kg	°	°	Lt/min	Kg
DG-K300	DGF018DG	12	1	3,00	250	20	400	20	450
DG-K400	DGF019DG	20	4	4,00	450	20	400	30	700
DG-K500	DGF020DG	25	4	5,00	550	20	400	35	900
DG-K600	DGF021DG	30	4	6,00	550	20	400	45	1100

CARICATORE FORESTALE – FORESTRY CRANE – GRUE FORESTIERE

SERIE "L"



Carico rapido e preciso con il sistema a parallelogramma

Fast and precise loading with the parallelogram system

Chargement rapide et précis avec le système de parallélogramme

I gru forestali serie DG-K hanno la caratteristica principale di non essere ripieghevoli a "Z" e quindi adatte prevalentemente per il loro posizionamento sopra rimorchi forestali oppure su trattori in posizione orizzontale sopra di essi. Sono macchine molto robuste con diverse estensioni e capacità di carico che permettono di adattarsi agli impieghi più gravosi, e di garantire un sistema di lavoro preciso e veloce. Sono dotati di doppia cremagliera per la rotazione e di un sistema a parallelogramma in grado di raggiungere ottime angolazioni di lavoro.



Doppia cremagliera per grandi potenze in rotazione

Double rack for big rotating powers

Double rack pour une grande puissance en rotation

The DG-K series cranes have the main characteristic of not being folded to „Z" and therefore suitable mainly for their positioning on forest trailers or on tractors in a horizontal position above them. They are very robust machines with different extensions and load capacities that allow them to adapt to the most demanding jobs, and to guarantee a precise and fast working system. They are equipped with a double rack for rotation and a parallelogram system able to reach optimal working angles.



Stabilizzatori verticali o con apertura a compasso

Vertical stabilizers or with compass opening

Stabilisateurs verticaux ou avec ouverture de la boussole

Les grues de la série DG-K ont la caractéristique principale de ne pas être pliées en «Z» et donc adaptées principalement à leur positionnement sur des remorques forestières ou sur des tracteurs en position horizontale au-dessus d'elles. Ce sont des machines très robustes avec des extensions et des capacités de charge différentes qui leur permettent de s'adapter aux tâches les plus exigeantes et de garantir un système de travail précis et rapide. Ils sont équipés d'une double crémaillère pour la rotation et d'un système de parallélogramme capable d'atteindre des angles de travail optimaux.

ACCESSORI FORESTALI – FORESTRY TOOLS – OUTILS FORESTIERE

NUOVO SISTEMA DI CONTROLLO ELETTRICO PROPORZIONALE NEW ELECTRIC SYSTEM FOR PROPORTIONAL CONTROL OF CRANE NOUVEAU SYSTÈME DE CONTRÔLE PROPORTIONNEL ÉLECTRIQUE DE GRUE



Il nuovo sistema DAGI ELECTRIC SYSTEM permette di controllare i movimenti della gru forestale direttamente da terra, dalla cabina del trattore o da una certa distanza, senza dover necessariamente essere seduti sopra la macchina. Il punto di forza di questo sistema è generato dalla grande sensibilità e precisione di movimento, oltreché una comodità di utilizzo mai vista prima in grado di garantire una visuale e comodità di lavoro in ogni situazione.

The new DAGI ELECTRIC SYSTEM allows you to control the movements of the forestry crane directly from the ground, from the tractor cab or from a distance, without necessarily having to sit on the machine. The strength of this system is generated by the great sensitivity and precision of movement, as well as a convenience of use never seen before able to guarantee a visual and working comfort in every situation.

Le nouveau SYSTÈME ÉLECTRIQUE DAGI vous permet de contrôler les mouvements de la grue forestière directement depuis le sol, depuis la cabine du tracteur ou à distance, sans devoir nécessairement vous asseoir sur la machine. La force de ce système est générée par la grande sensibilité et la précision du mouvement, ainsi qu'une commodité d'utilisation jamais vue auparavant capable de garantir un confort visuel et de travail dans toutes les situations.

BRACCIO PER ESBOSCO – PINCE DE DEBARDAGE – TIMBER LOADING GRAPPLE



Caratteristiche tecniche Technical features		PZE 1700	PZE 2200
Apertura Massima Maximum opening	mm	1700	2200
Chiusura minimo Minimum closure	mm	70	70
Peso Weight	Kg	380	450



POLIPI, FORCHE E BENNE – POLYP, FORK AND BUCKET – POLYPE, FOURCHE ET GODET



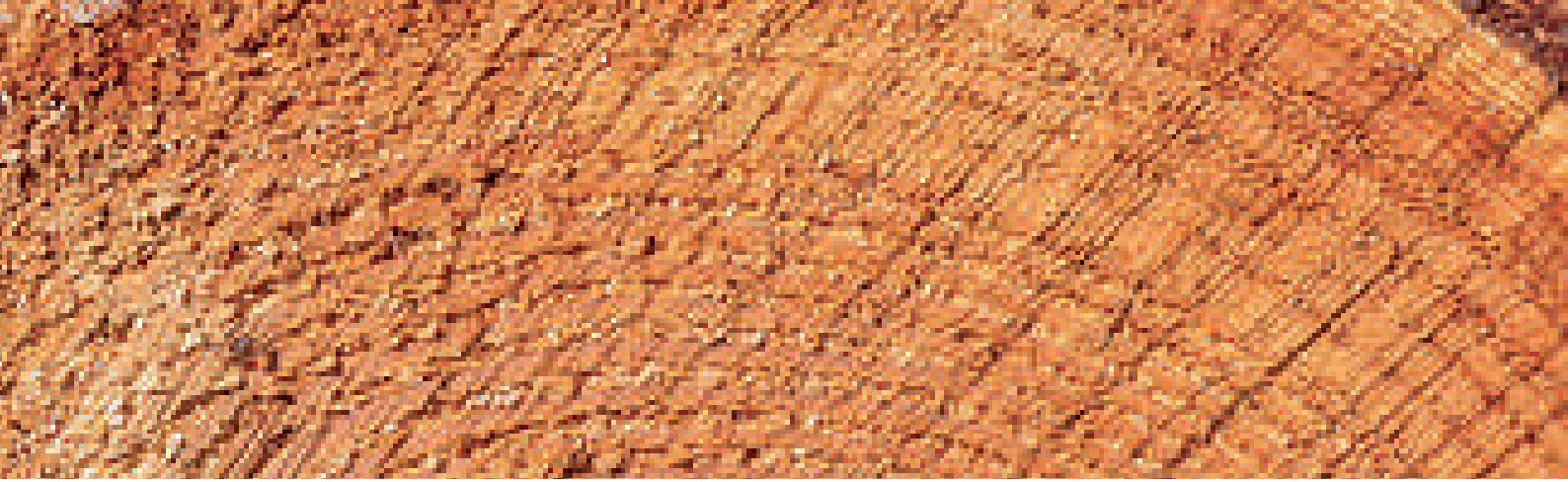

Daniele & Giraud snc
Via Levaldigi, 9
12020 Vottignasco (CN)
ITALY
Tel. +39 0171 941020
Fax. +39 0171 941263
www.danieleegiraud.com
info@danieleegiraud.com

DANIELE & GIRAUDO